

2 - Wash Hood

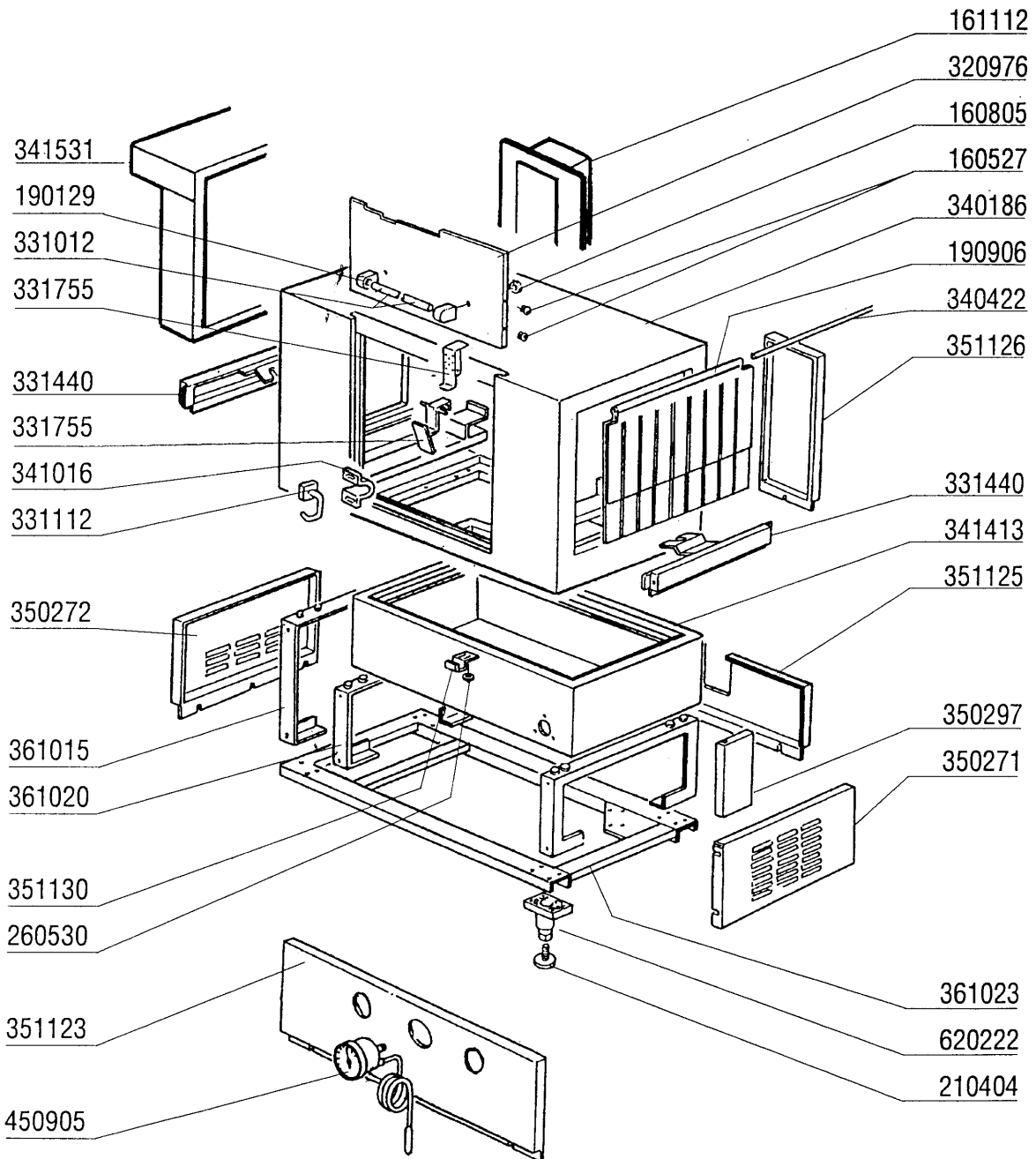

2 - Wash Hood

CODE	DESCRIPTION
160527	PLUG 14,5X2X8
160805	GASKET D.8
161112	BACK COVER CHANNEL 300 S N
190129	HANDLE SUPPORT SE NE GREY
190906	CURTAIN IN/OUT 620X480
210404	BLACK RUBBER FOOT S90 NE SE
260530	STAINL.ST WASHER 7X22X2
320976	DOOR
331012	HANDLE 412 MM DOOR SE NE G115
331112	HOOK (331116)
331440	PANEL
331755	HOOK FOR DOOR SUPPORT
340186	WASH HOOD
340422	SHAFT FOR CURTAIN AC-ACR
341016	BRAKET FOR DOOR SECURITY HOOK
341413	WASH TANK 1300
341531	HOOD
350271	PANEL
350272	PANEL
350297	PANEL
351123	FRONT PANEL WASH S2200-2900
351125	PANEL
351126	PANEL
351130	BRACKET FOR PANEL S-SE
361015	FRAME
361020	FRAME
361023	FRAME
450905	CAPIL.THERMOMETER D.52 1,5M
620222	COMPLETE ALUMINIUM LEGS

3 - Blower Dryer hood

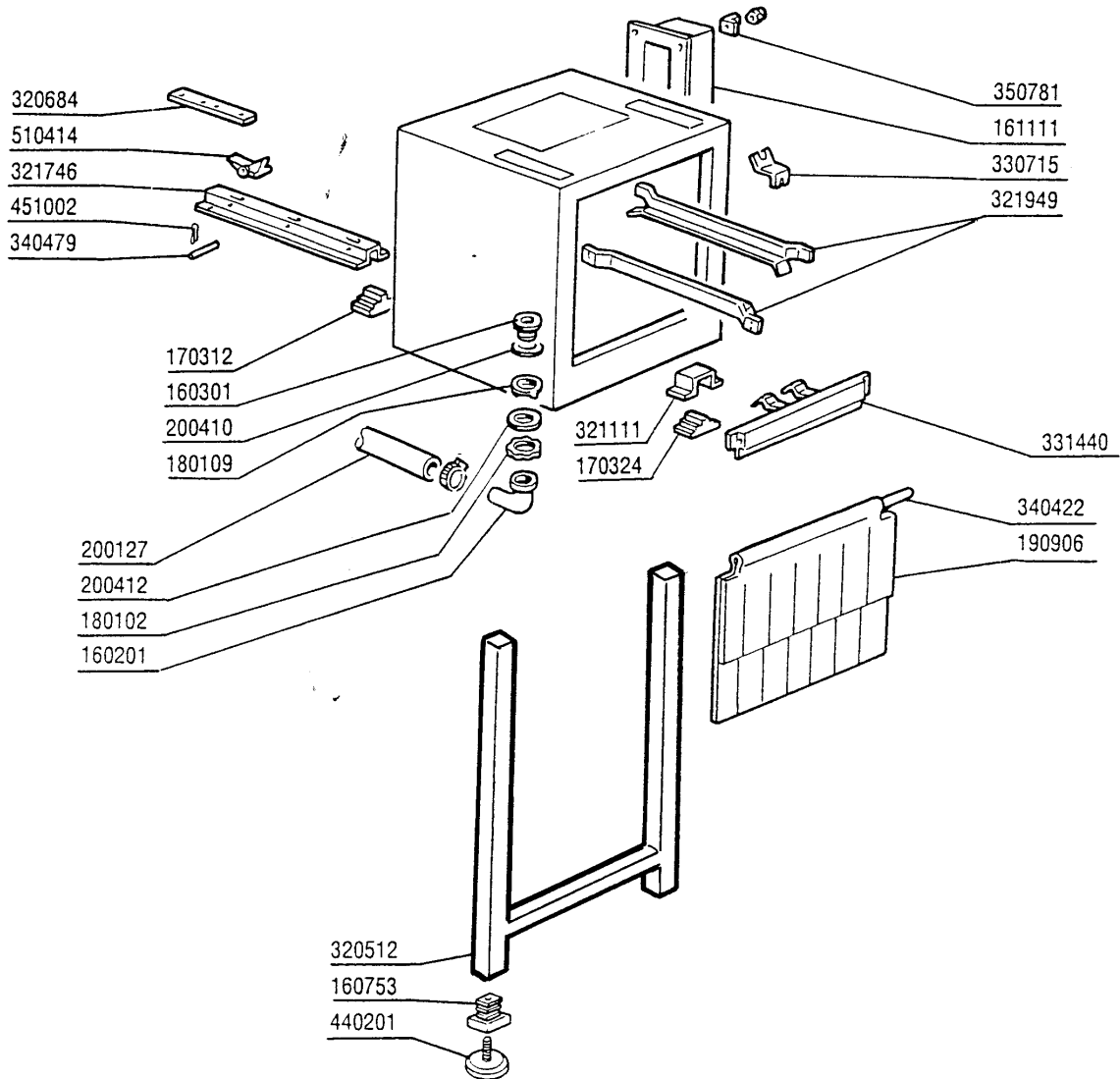

3 - Blower Dryer hood

CODE	DESCRIPTION
160201	ELBOW F.TANK INLET MOPLEN
160301	DRAIN OUTLET 1"1/2 C-S-N
160753	PLUG 40X40X1
161111	BACK COVER CHANNEL 130 N S2900
170312	SUPPORT F.PAWL BAR GUIDE S90-
170324	GUIDE SUPPORT SE-S2200-290
180102	DRAIN PIPE NUT 1"1/2 F45-55
180109	LOCK NUT 1 1/2"
190906	CURTAIN IN/OUT 620X480
200127	PVC HOSE D.35
200410	DRAIN OUTL.WASH.1 1/2"65X47X2
200412	GASKET DRAIN 11/2" 45X33X3
320512	TABLES LEG
320684	BRACKET
321111	COVER
321746	GUIDE
321949	GUIDE
330715	UPPER BRACKET CURTAIN SNL-SE
331440	PANEL
340422	SHAFT FOR CURTAIN AC-ACR
340479	PAWL PINS SNL-SE
350781	BRACKET
440201	RUBBER FOOT D.60X10
451002	COTTER PIN STAINL.ST. D2X12
510414	NICKEL-PLATED PAWL SNL-SE

4 - Wash Tank Components

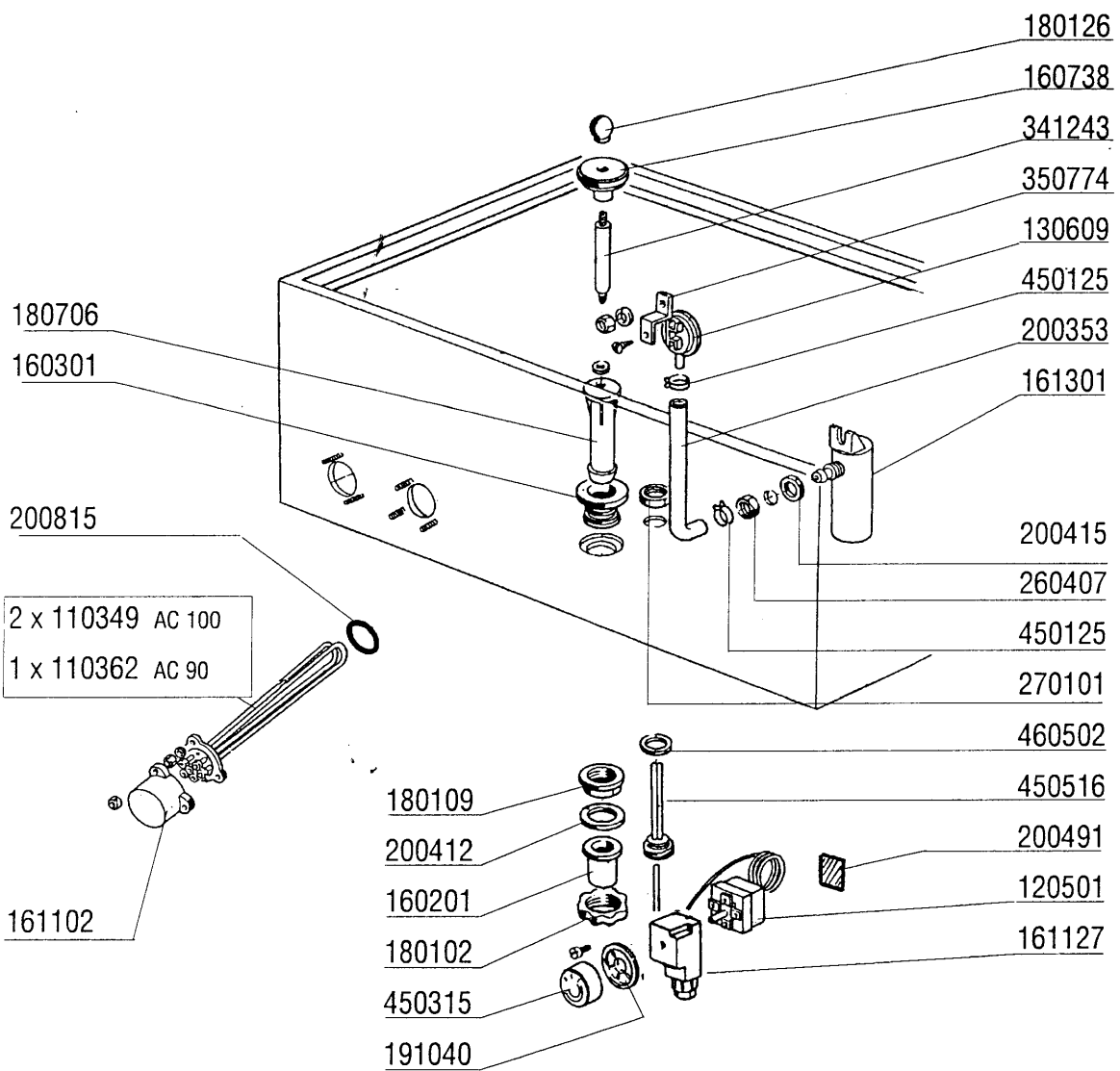

4 - Wash Tank Components

CODE	DESCRIPTION
110349	HEAT.ELEMENT 6000W 230/400V
110362	HEAT.ELEMENT 9000W 220/380V
120501	THERMOSTAT 30/90°C
130609	1 LEVEL PRESSURE SWITCH 110-70
160201	ELBOW F.TANK INLET MOPLN
160301	DRAIN OUTLET 1"1/2 C-S-N
160738	COVER PLATE F.OVERFLOW PIPE S2
161102	ELEMENT COVER MOPL.
161127	BOX FOR THERMOSTAT
161301	AIR TRAP F2 C34-F45
180102	DRAIN PIPE NUT 1"1/2 F45-55
180109	LOCK NUT 1 1/2"
180126	HANDLE F.OVERFLOW PIPE SNL
180706	OVERFLOW STANDPIPE S3 - S NEW
191040	FRAME F.THERMOSTAT KNOB
200353	PRESS.SWITCH HOSE B23-10-1-2-C
200412	GASKET DRAIN 11/2" 45X33X3
200415	AIR TRAP GASKET -F2 18,5X10X3
200491	BACK GASKET OF THERMOSTAT BOX
200815	O-RING F. HEAT.ELEM.
260407	STAINLESS STEEL NUTS D10 UNI 5
270101	HEXAGON LOCK NUT 1/2"
341243	SHAFT FOR SNL/AC90 OVERFLOW
350774	BRACKET
450125	ELASTIC CLAMP D. 10,4X9,8
450315	KNOB F. THERMOSTAT 90°
450516	THERMOSTAT SHIELD FOR 2 TERMOS
460502	GASKET 30X21X2

5 - Wash Assembly AC90

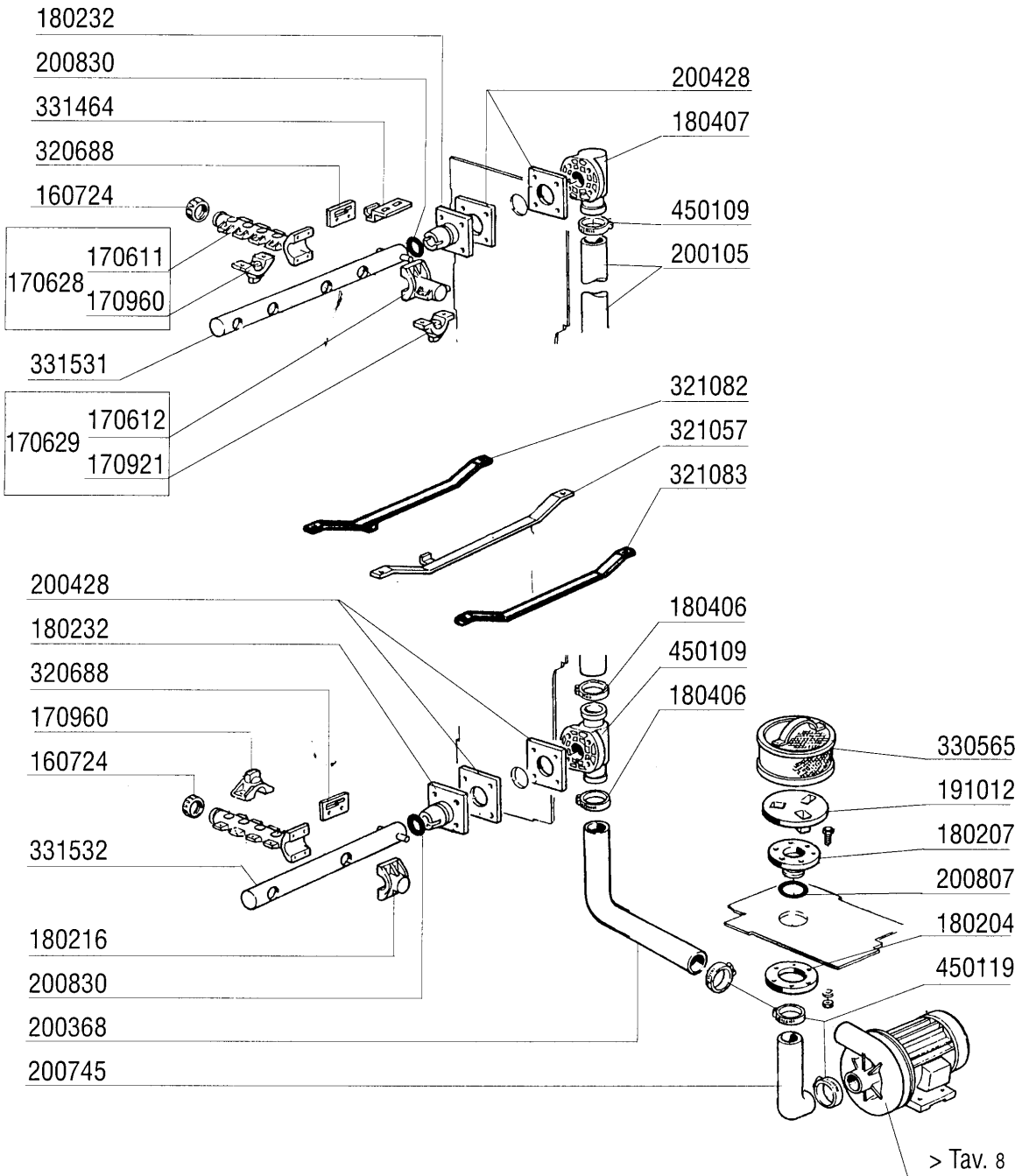

5 - Wash Assembly AC90

CODE	DESCRIPTION
160724	PLUG F. WASH ARM S90
170611	LONG WASH ARM S90 -S N L
170612	SHORT WASH ARM S90-S2900
170628	WASH ARM ASSEMBLY S1600
170629	SHORT WASH ARM ASSEMBLY
170921	AXIAL WASH NOZZLE D 35
170960	WASH JET 4,5
180204	COUNTERFLANGE D.130 SUCTION N
180207	SUCTION FLANGE C33/34
180216	WASH ARM COUNTERFLANGE S90-S N
180232	WASH ARM FLANGE SNL
180406	T-CONNECTOR F. WASHING S90-SNL
180407	ELBOW S90 S N L
191012	VOTEX BREAKER S3ØN.L. G65
200105	RUBBER HOSE 50X60
200368	OUTLET HOSE S90-S N L
200428	GASKET 100X100X3 NEOTEN
200745	INLET HOSE WASH. SNL
200807	O-RING 3,53 X 110,72
200830	O-RING 37,3X44,5X3,6
320688	SUPPORT FOR S/AC WASHARM
321057	LOWER WASH ARM SUPPORT
321082	SUPPORT
321083	SUPPORT FOR "S" LOWER WASHARM
330565	FILTER 185X100H SE NE SNL
331464	SUPPORT FOR UPPER WASH ARM
331531	UPPER WASH ARM SNL
331532	LOWER WASH ARM AC91/101
450109	CLAMP 50-65
450119	CLAMP FE ZN. 58-75 H=12,2

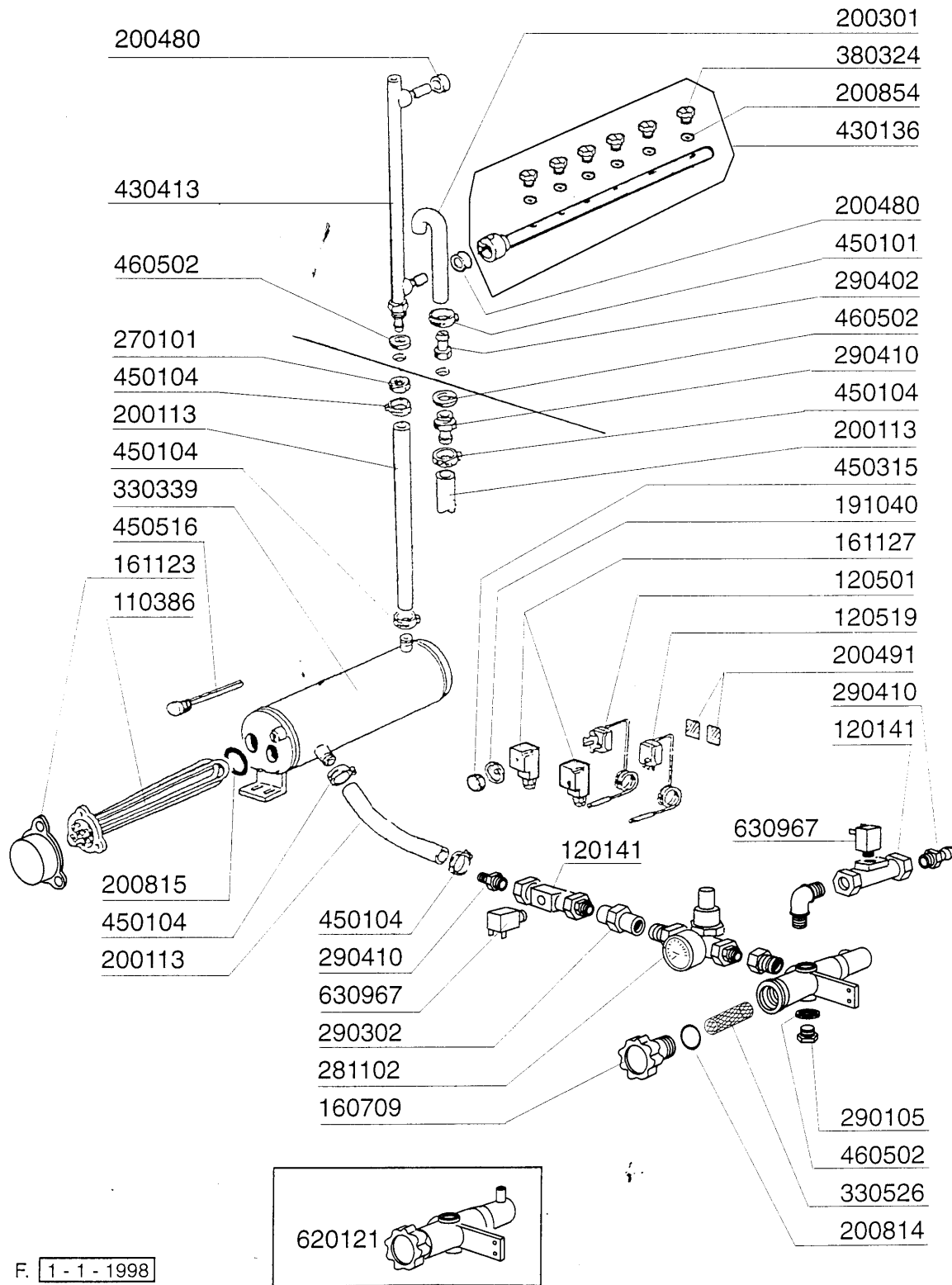

F. 1 - 1 - 1998

CODE	DESCRIPTION
110386	HEAT.ELEMENT14KW 230/400V
120141	SOLEN.VALVE METAL.328000 D.1/2
120501	THERMOSTAT 30/90ØC
120519	SECURITY THERMOSTAT 95-125Ø
160709	KNOB OF MANIFOLD F. SOLEN. VAL
161123	HEAT.ELEMENT COVER H42 SNL
161127	BOX FOR THERMOSTAT
191040	FRAME F.THERMOSTAT KNOB
200113	RUBBER HOSE 12 X 22
200301	HOSE FOR TANK INLET N-S
200480	GASKET F. RINSE CONNECT.
200491	BACK GASKET OF THERMOSTAT BOX
200814	O-RING 34,52X41,58X3,53
200815	O-RING F. HEAT.ELEM.
200854	O-RING FOR NOZZLE OF S/S RINSE
270101	HEXAGON LOCK NUT 1/2"
281102	1/2" ADJ VALVE C/W GAUGE TYPE
290105	BRASS-TE-PLUG 1/2"
290302	BRASS CONNECTING TUBE F.F. 3/4
290402	NIPPLE F.1/2" BRASS
290410	NIPPLE 1/2"
330339	BOILER D.220X640 F.TWO HEAT.EL
330526	FILTERS 22X28 SOLENOID V.MANIF
380324	RINSE JETS 52,5 80Ø OV1/8"
430136	RINSE ARM S-SE-SE/1
430413	RINSE COLUMN SE-ACR
450101	STAINLESS STEEL CLAMP 15-24 H=
450104	CLAMP FE ZN H=12,5 15-24
450315	KNOB F. THERMOSTAT 90Ø
450516	THERMOSTAT SHIELD FOR 2 TERMOS
460502	GASKET 30X21X2
620121	TWIN SOLENOID VALVE MANIFOLD
630967	COIL V24/50HZ E/V 328002

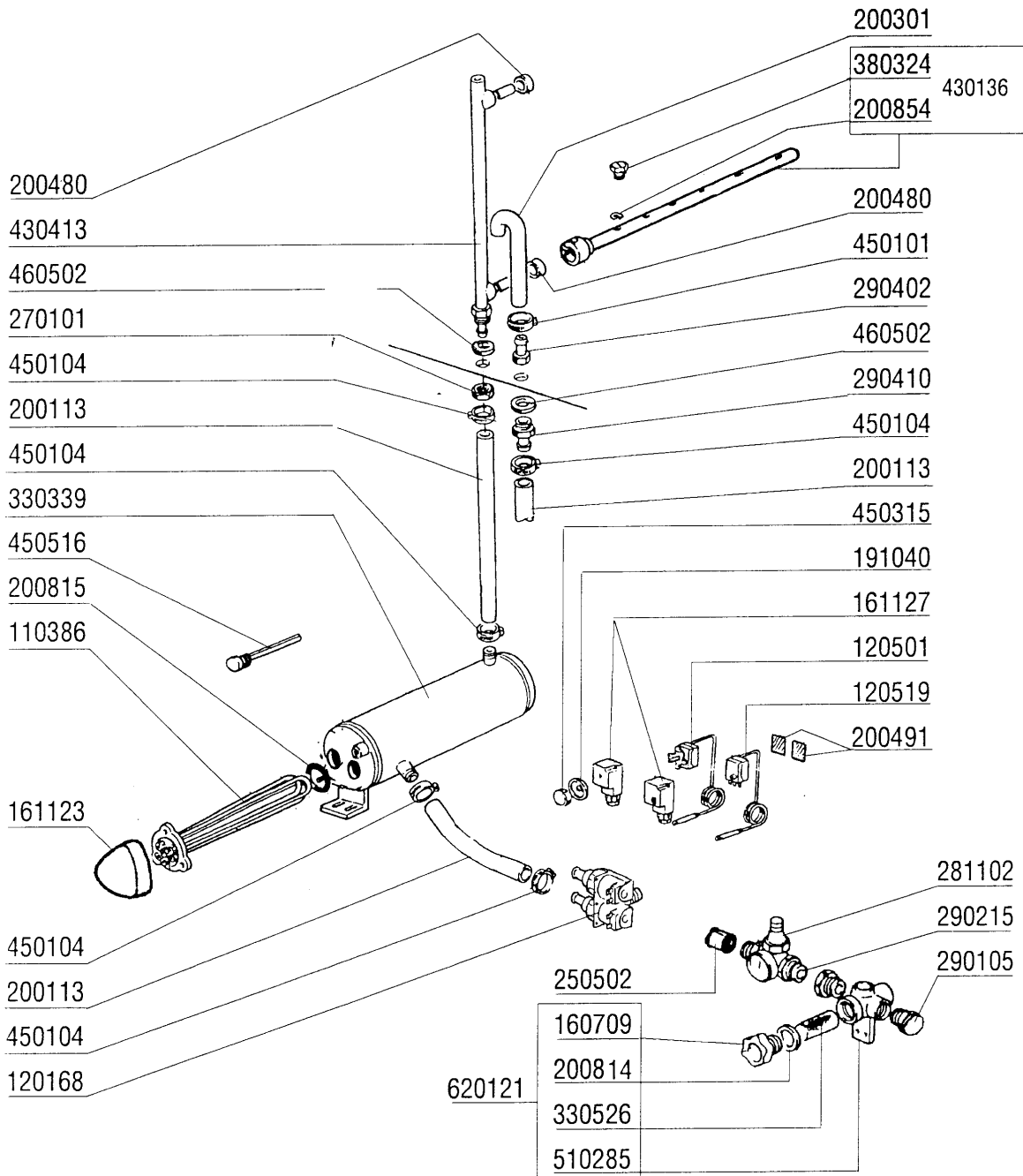

7 - Rinse AC90

CODE	DESCRIPTION
110386	HEAT.ELEMENT14KW 230/400V
120168	2-WAY SOLENOI VALVE 24V
120501	THERMOSTAT 30/90ØC
120519	SECURITY THERMOSTAT 95-125Ø
160709	KNOB OF MANIFOLD F. SOLEN. VAL
161123	HEAT.ELEMENT COVER H42 SNL
161127	BOX FOR THERMOSTAT
191040	FRAME F.THERMOSTAT KNOB
200113	RUBBER HOSE 12 X 22
200301	HOSE FOR TANK INLET N-S
200480	GASKET F. RINSE CONNECT.
200491	BACK GASKET OF THERMOSTAT BOX
200814	O-RING 34,52X41,58X3,53
200815	O-RING F. HEAT.ELEM.
200854	O-RING FOR NOZZLE OF S/S RINSE
250502	ELBOW 3/4" ST/ST
270101	HEXAGON LOCK NUT 1/2"
281102	1/2" ADJ VALVE C/W GAUGE TYPE
290105	BRASS-TE-PLUG 1/2"
290215	1/2"BSP M/F UNION BRASS
290402	NIPPLE F.1/2" BRASS
290410	NIPPLE 1/2"
330339	BOILER D.220X640 F.TWO HEAT.EL
330526	FILTERS 22X28 SOLENOID V.MANIF
380324	RINSE JETS 52,5 80Ø OV1/8"
430136	RINSE ARM S-SE-SE/1
430413	RINSE COLUMN SE-ACR
450101	STAINLESS STEEL CLAMP 15-24 H=
450104	CLAMP FE ZN H=12,5 15-24
450315	KNOB F. THERMOSTAT 90Ø
450516	THERMOSTAT SHIELD FOR 2 TERMOS
460502	GASKET 30X21X2
510285	SOLENOID VALVE MANIFOLD - BRAS
620121	TWIN SOLENOID VALVE MANIFOLD

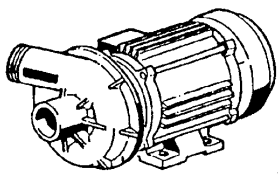

100361 (220/380 V 50 Hz)
(240/415 V 50 Hz)

100605 (220/380 V 60 Hz)

100613 (250/440 V 60 Hz)

631618 (50 Hz)
631647 (60 Hz)

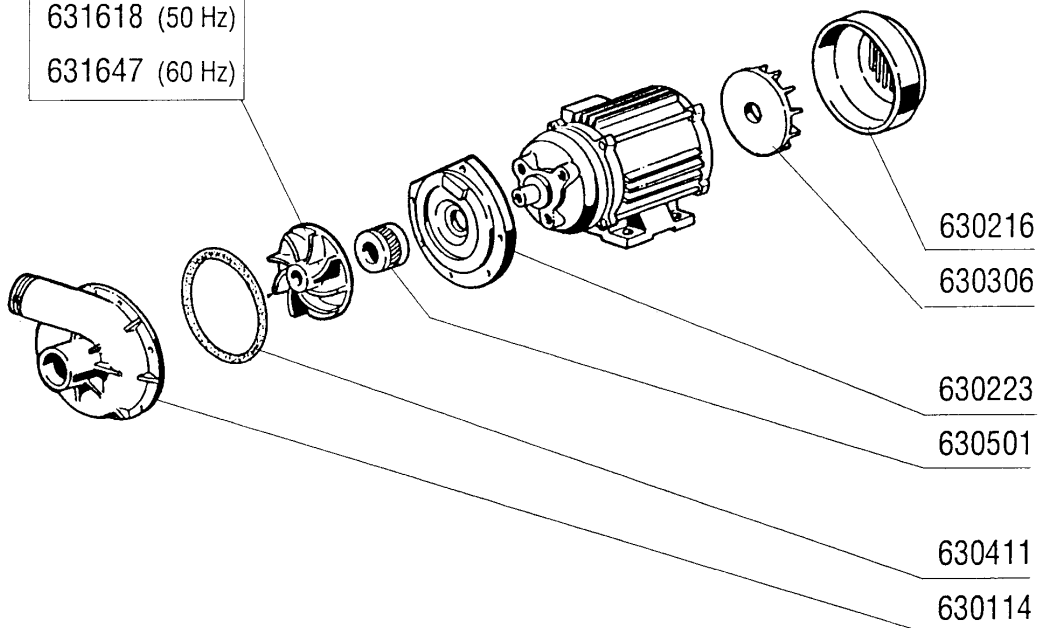

8 - Pump 2HP

CODE	DESCRIPTION
100361	PUMP HP 2-220/380-50HZ-120404
100605	PUMP HP 2 380/3/60HZ 1204
100613	PUMP HP 2 440/3/60HZ 1204
630114	VOLUTE FI HP2-2,7-3-3,2
630216	FAN HOUSING FIR HP 2-3
630223	BACK PLATE PUMP HP2-3-3,2
630306	PUMP FAN IMPELLOR FI HP.2-3
630411	O-RING PUMP FI HP 2-2,7
630501	SEAL FOR PUMP HP 2-3-3,2
631618	IMPELLER PUMP F HP2-D.116,5
631647	IMPELLER D.100-60HZ-1204/5

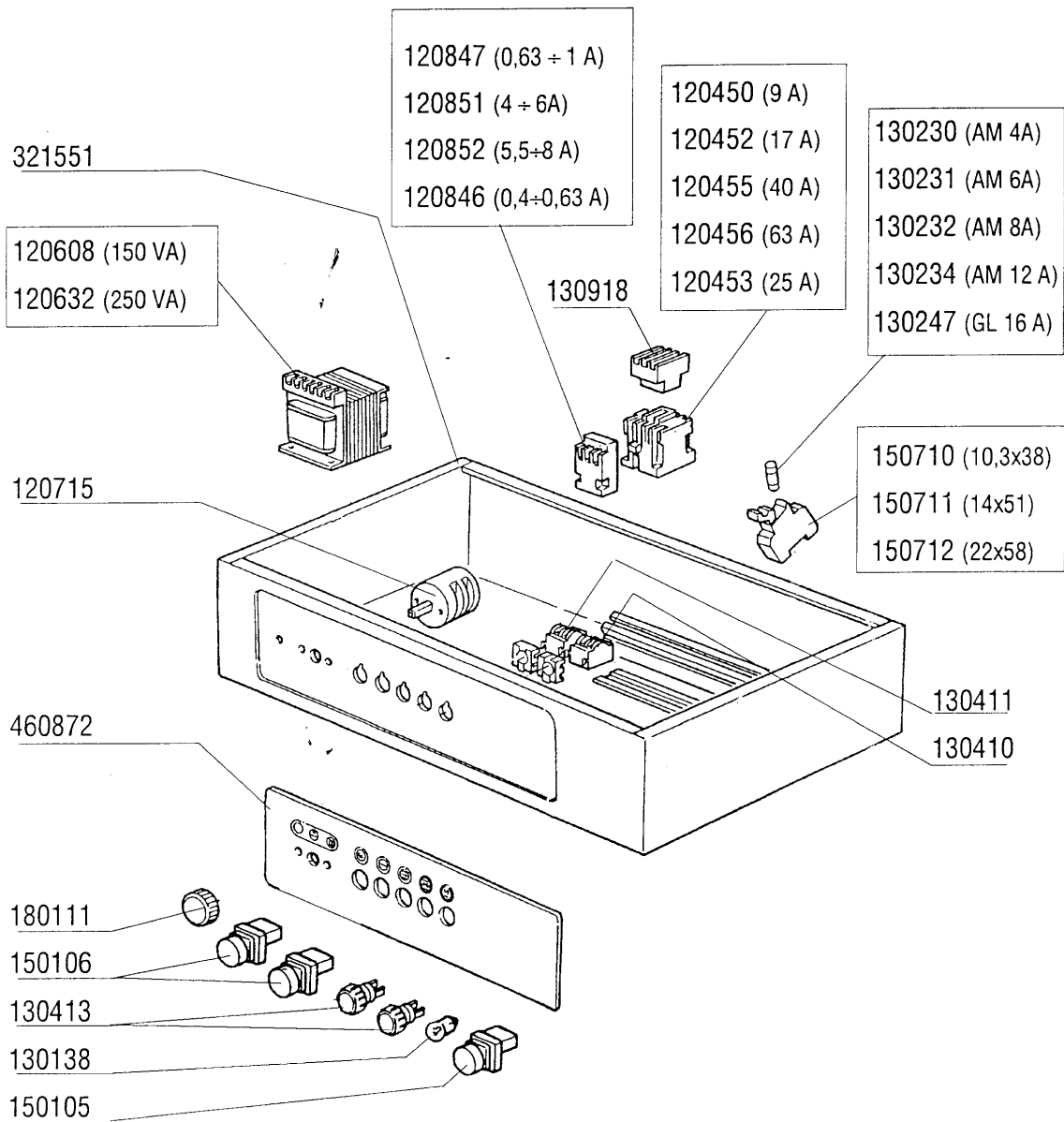

9 - Control Box AC90

CODE	DESCRIPTION
120450	CONTACTOR 9A 24V 4KW
120452	CONTACTOR 18A 24V 7,5KW 3TF320
120453	CONTACTOR 25A 24V 11KW 3TF3300
120455	CONTACTOR 40A 24V 18,5KW 3TF35
120456	CONTACTOR 63A 24V 30KW
120608	TRANSFORMER 150VA220-240-380-4
120632	TRANSFORMER 250VA220-240-380-4
120715	MAIN SWITCH 16A 4 POLES
120846	OVERLOAD RELAY 0,4/0,63A
120847	OVERLOAD RELAY 0,63/1A
120851	OVERLOAD RELAY 4/6A
120852	OVERLOAD RELAY 5/8A
130138	LIGHT WITH BAYONET COUPLING 3W
130230	FUSE 10,3X38 4A AM13004
130231	FUSE 10,3X38 6A AM13006
130232	FUSE 10,3X38 8A AM13008
130234	FUSE 10,3X38 12A AM13012
130247	FUSE 10,3X38 16A GF13316
130410	STOP CONTACT F40 CN RED
130411	START CONTACT YELLOW
130413	GREEN PUSH BUTTON
130918	CONTACT NO 3TX4010 2A
150105	LAMP RED D.22X5
150106	LAMP GREEN 22X5
150710	FUSE CARRIER 10,3X38 ART.21401
150711	FUSE CARRIER 14X51 ART.21501
150712	FUSE CARRIER 22X58 ART.21601
180111	BLACK KNOB
321551	BOX
460872	CONTROL PANEL S1600 -AC90

10 - Rack guide - Door+rinse switches

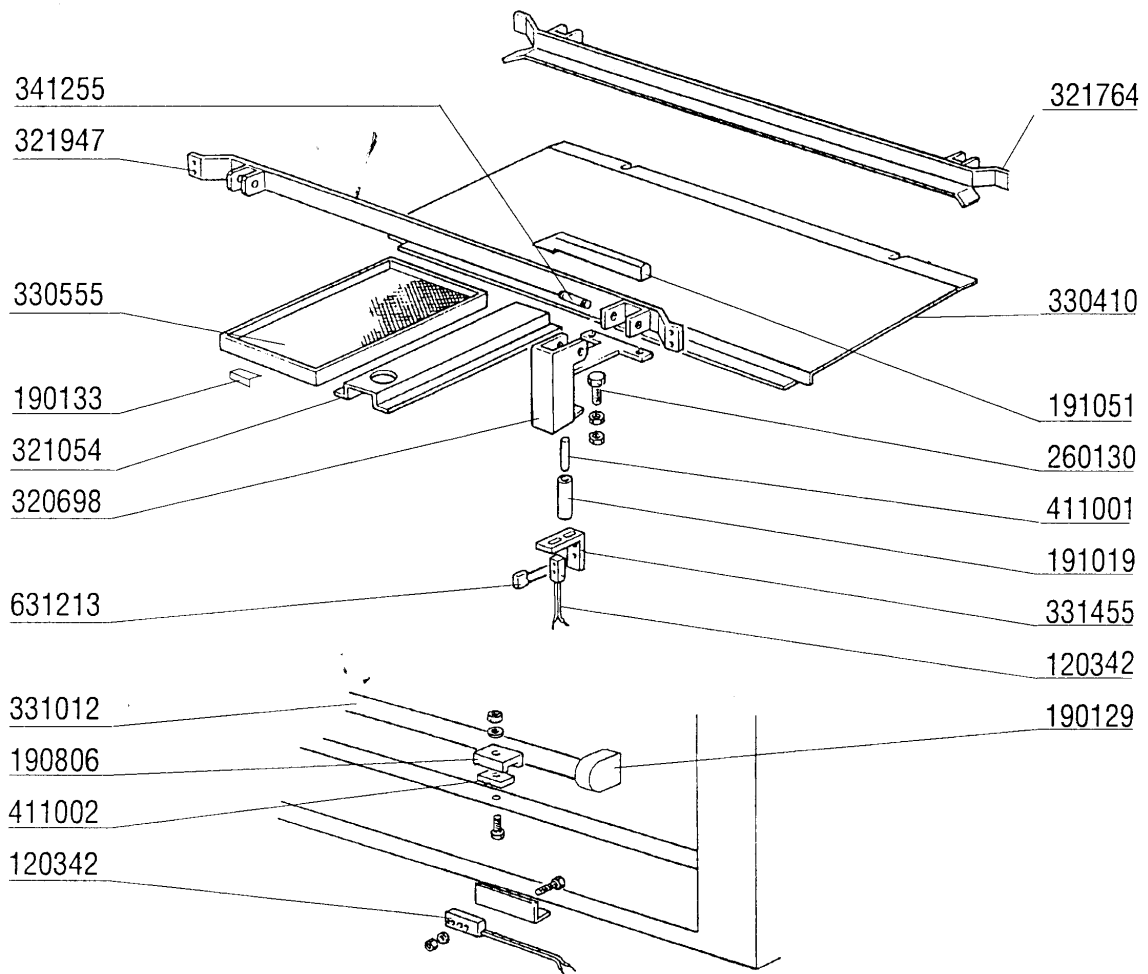

10 - Rack guide - Door+rinse switches

CODE	DESCRIPTION
120342	DOR MAGNETIC SWITCH
190129	HANDLE SUPPORT SE NE GREY
190133	STRAINER SUPPORT SE SNL
190806	MAGNET HOUSING
191019	MAGNET HOUSING S90 MOPL.-S.N.L
191051	SLIDING PAD SE SNL ECONOMIZER
260130	SCREW TE 10X50 S/S
320698	LEVER FOR ECONOMIZER SE SNL
321054	SUPPORT
321764	GUIDE
321947	GUIDE
330410	-SCIVOLO PER LAV.S2200-2900***
330555	WASH FILTER SE-S2200-2900
331012	HANDLE 412 MM DOOR SE NE G115
331455	BRACKET FOR RINSE MICROSWITCH
341255	PIN FOR ECONOMIZER SE SNL
411001	PERMANENT MAGNET 8X40
411002	PERMANENT MAGNET 24X12
631213	CAPACITOR 0,1MF

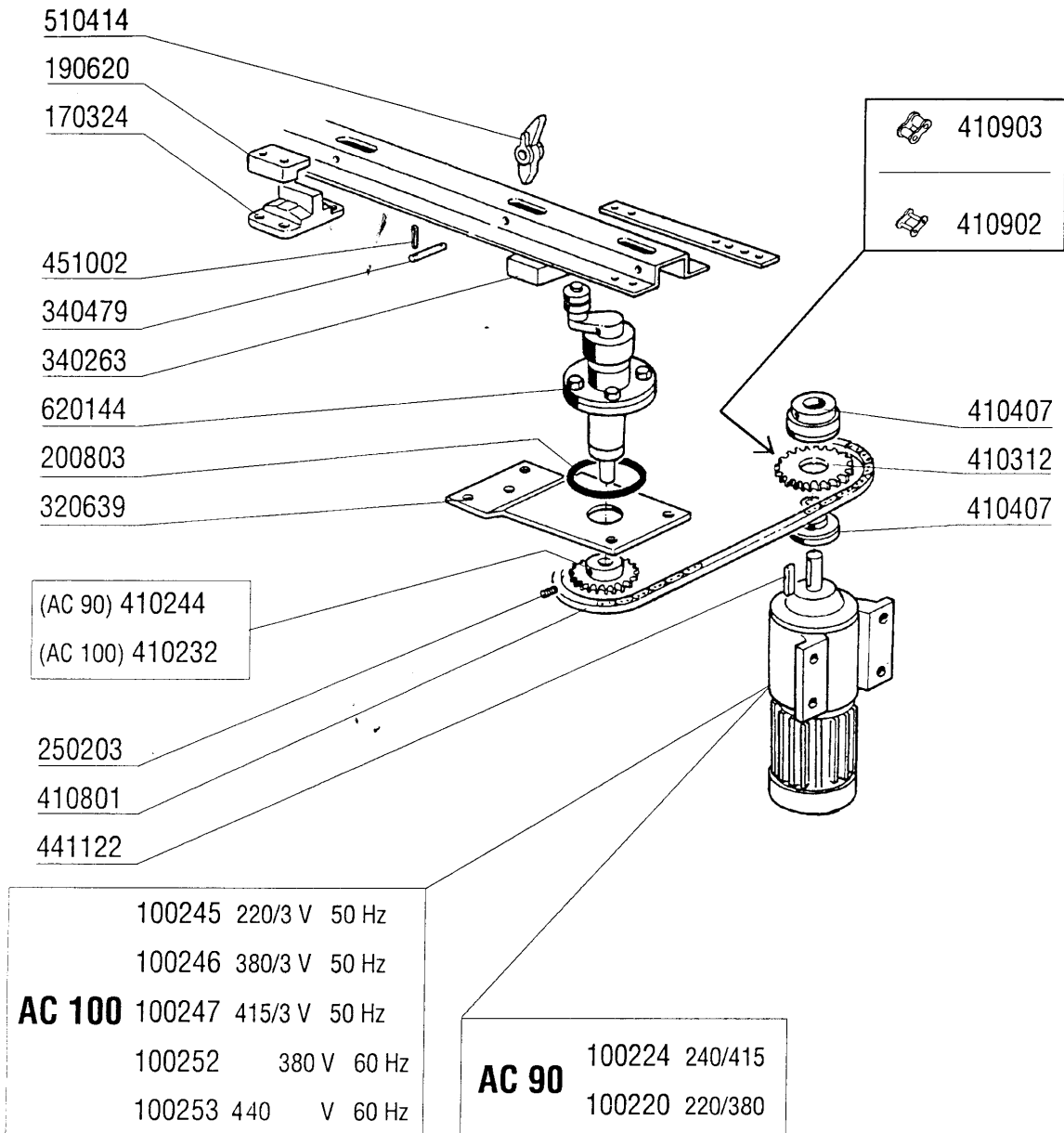

11 - Drive unit

CODE	DESCRIPTION
100220	DRIVE MOTOR KW0,12-220/380V/50
100224	DRIVE MOTOR 0,12KW
100245	DRIVE MOTOR 220/3 (100246)
100246	DRIVE KW 0,1-0,15 380/3
100247	DRIVE KW 0,1-0,15 415/3 SK01-7
100252	DRIVE MOTOR 0,1-0,15KW 380/60
100253	DRIVE MOTOR 0,1-0,15KW 440/60
170324	GUIDE SUPPORT SE-S2200-290
190620	CLAMPING PIECES S 3
200803	OR GASKET 3,53X98,02X105,08
250203	GRUB SCREW 8X12
320639	PLATE
340263	CHANNEL FOR BEARING S90-S NEW
340479	PAWL PINS SNL-SE
410232	TURNED PINION Z25-1/2"-D.20
410244	PINION Z34
410312	CROWN DISCS 22T
410407	TORQUE LIMITER LC 1
410801	DRIVE CHAIN 1/2" N-S
410902	FALSE CHAIN LINK 1/2"
410903	CHAIN JOINT 1/2"
441122	DRIVE SHAFT KEY 6X6X25 UNI 660
451002	COTTER PIN STAINL.ST. D2X12
510414	NICKEL-PLATED PAWL SNL-SE
620144	DRIVE ASSEMBLY

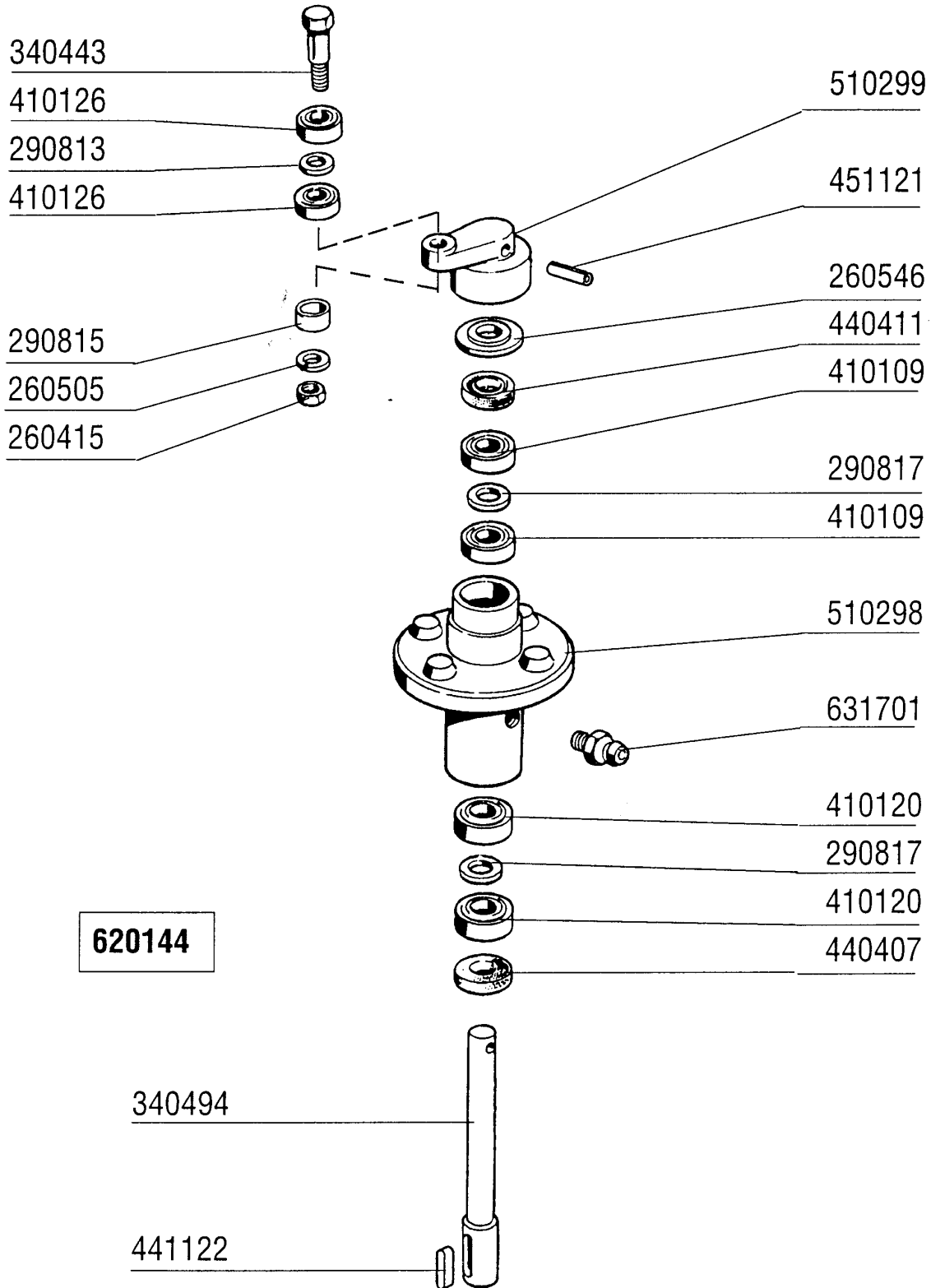

12 - Drive unit

CODE	DESCRIPTION
260415	STAINLESS STEEL SELF-LOCKING N
260505	STAINL.STEEL FLAT WASHER D8
260546	SLIDING WASHER STAINLESS STEEL
290813	PACKING PIECES BRASS S-F2
290815	DISTANCE PIECE S3Ø BRASS
290817	BRASS DISTANCE PIECE 24X14
340443	CRANK SHOULDER PIN
340494	DRIVE SHAFT S 3Ø
410109	BEARINGS 17X40X12 6203
410120	BALL BEARING 17X35X10
410126	BEARING 6201-2RS Z15
440407	SEAL MIM 20X35X7
440411	SEAL 17X40X7
441122	DRIVE SHAFT KEY 6X6X25 UNI 660
451121	ELAST.ROLL PINS 6X30
510298	DRIVE HOUSING S 3Ø
510299	NICKELPLATED BRASS DRIVE CRANK
620144	DRIVE ASSEMBLY
631701	GREASE NIPPLE 9003

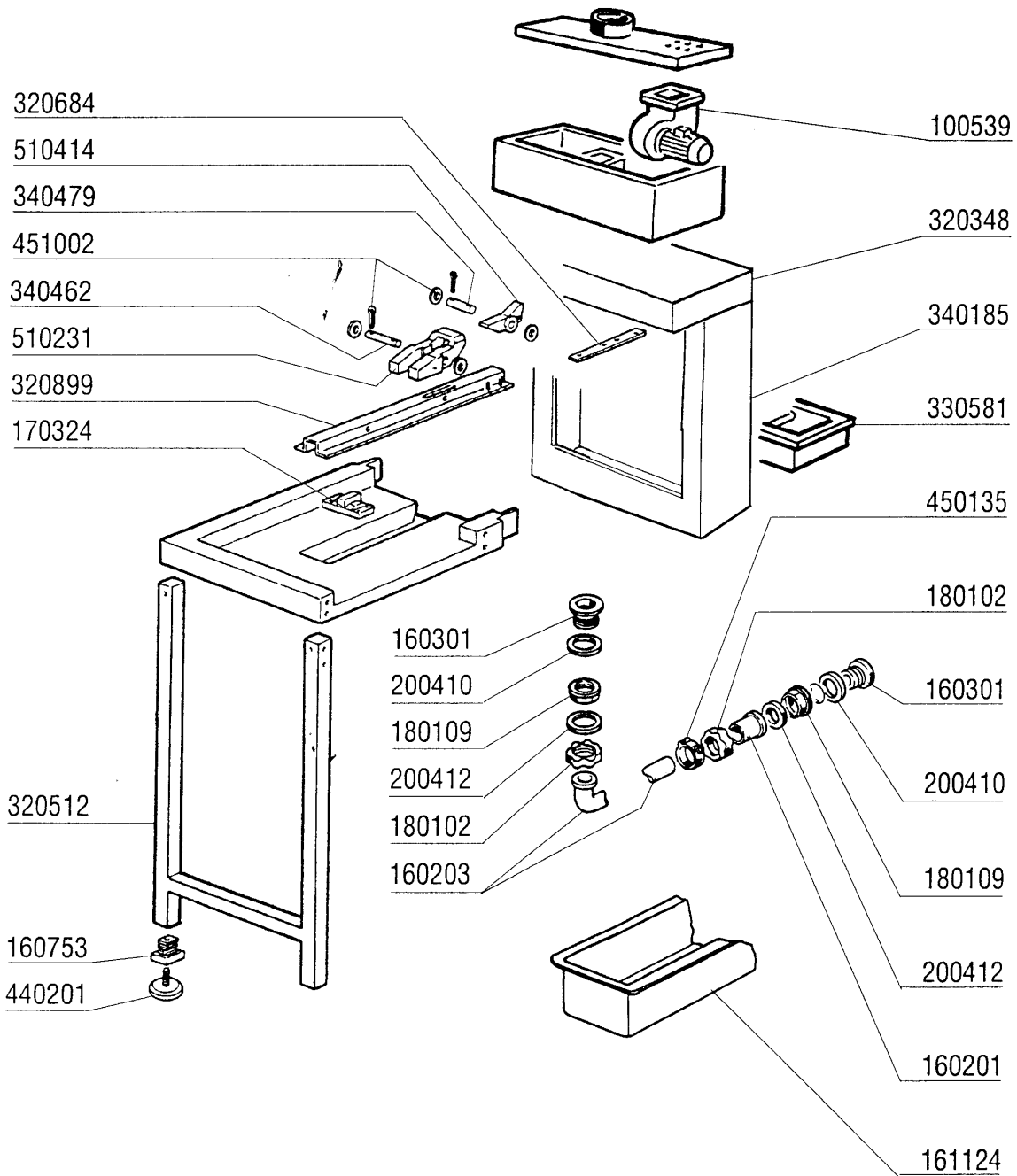

13 - Side Loading Table

CODE	DESCRIPTION
100539	EXHAUST FAN F.SPLASH GUARD 220
160201	ELBOW F.TANK INLET MOPLEN
160203	ELBOW 1"1/2 N-S-F-C /DRAIN
160301	DRAIN OUTLET 1"1/2 C-S-N
160753	PLUG 40X40X1
161124	DRYING OUTLET HOSE PROTECTION
170324	GUIDE SUPPORT SE-S2200-290
180102	DRAIN PIPE NUT 1"1/2 F45-55
180109	LOCK NUT 1 1/2"
200410	DRAIN OUTL.WASH.1 1/2"65X47X2
200412	GASKET DRAIN 11/2" 45X33X3
320348	BASE TOP FOR SPLASH HOOD
320512	TABLES LEG
320684	BRACKET
320899	GUIDE
330581	DRAWER FILTER EXTENTION HOODS
340185	HOOD
340462	SHORT TRAY CARRIER PIN GM-S290
340479	PAWL PINS SNL-SE
440201	RUBBER FOOT D.60X10
450135	CLAMP FE ZN. 44-56 H=12,2
451002	COTTER PIN STAINL.ST. D2X12
510231	PAWL /CORNER LOAD.
510414	NICKEL-PLATED PAWL SNL-SE

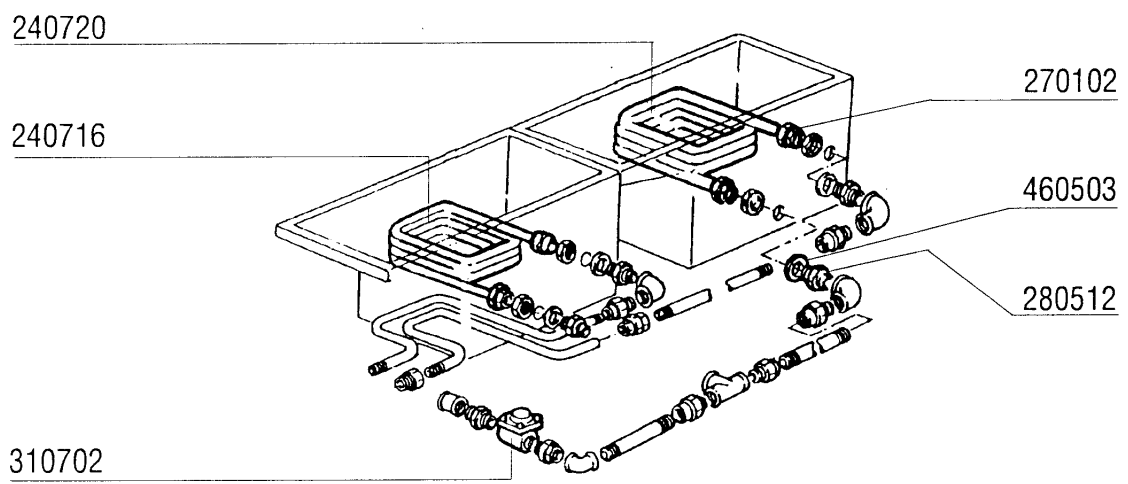
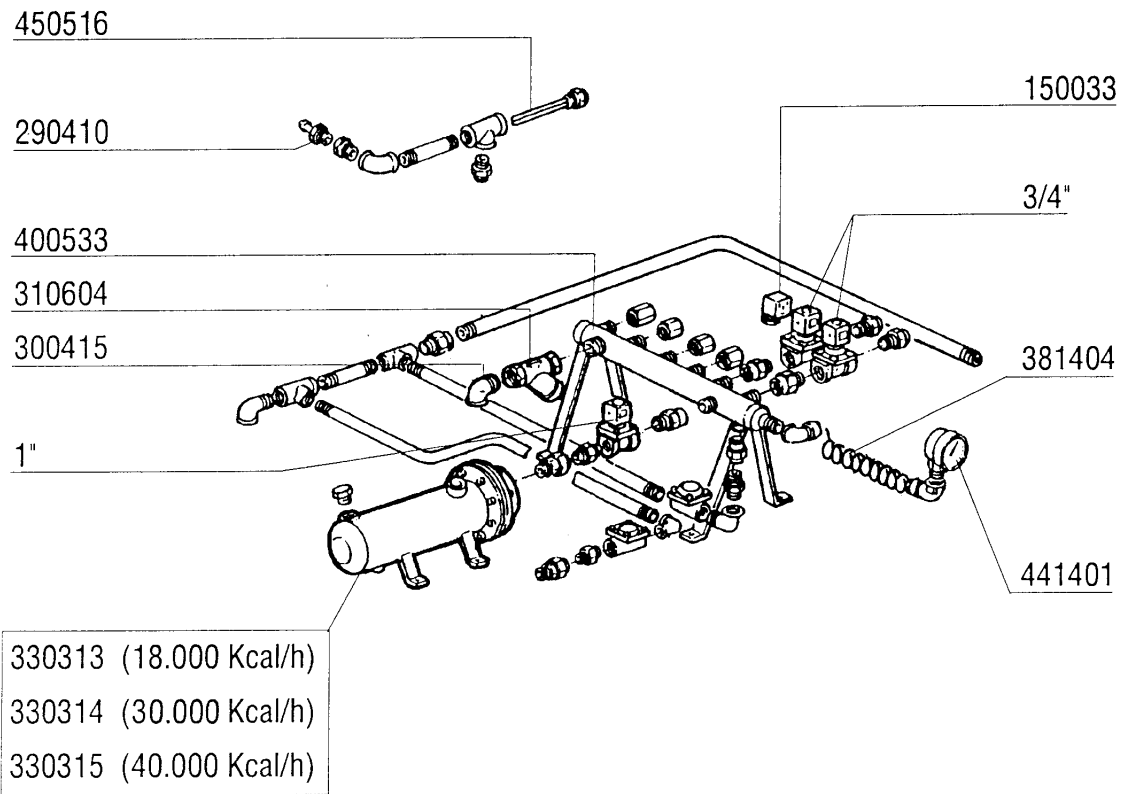

14 - Steam Version

CODE	DESCRIPTION
150033	CONNEC.F.SOLEN.VALVE 182.09.N
240716	STEAM COIL G66-S3
240720	S/S STEAM COIL 12.000KCAL ACR/
270102	LOCK NUT 3/4"
280512	STEAM COIL CONNECTION
290410	NIPPLE 1/2"
300415	ELL 2" MF
310604	STRAINERS JU 2" MOD.45
310702	STEAM TRAP 1/2" MK 25/3
330313	STEAM BOILER 18000KCAL/H
330314	STEAM BOILER 30000 KCAL/H
330315	STEAM BOILER 40000KCAL/H
381404	HOSE STEAM GAUGE
400533	ST/ST STEAM MANIFOLD FOR NE MA
441401	PRESSURE GAUGE 60 SCALO-4CR1/4
450516	THERMOSTAT SHIELD FOR 2 TERMOS
460503	SEALING WASHER 38X27X2(3/4)

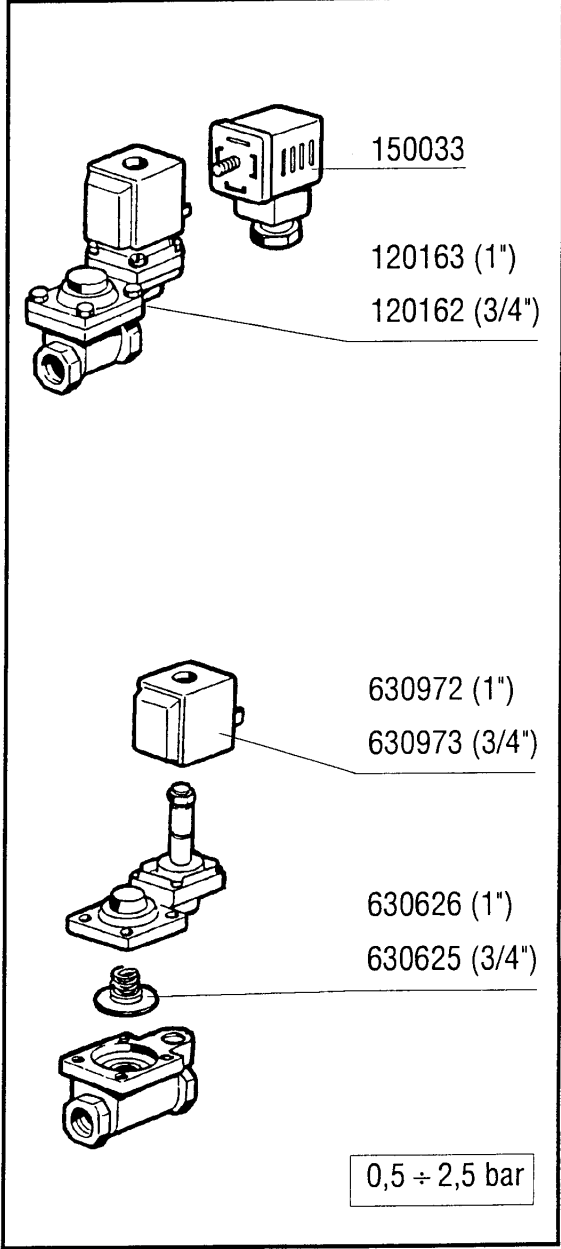
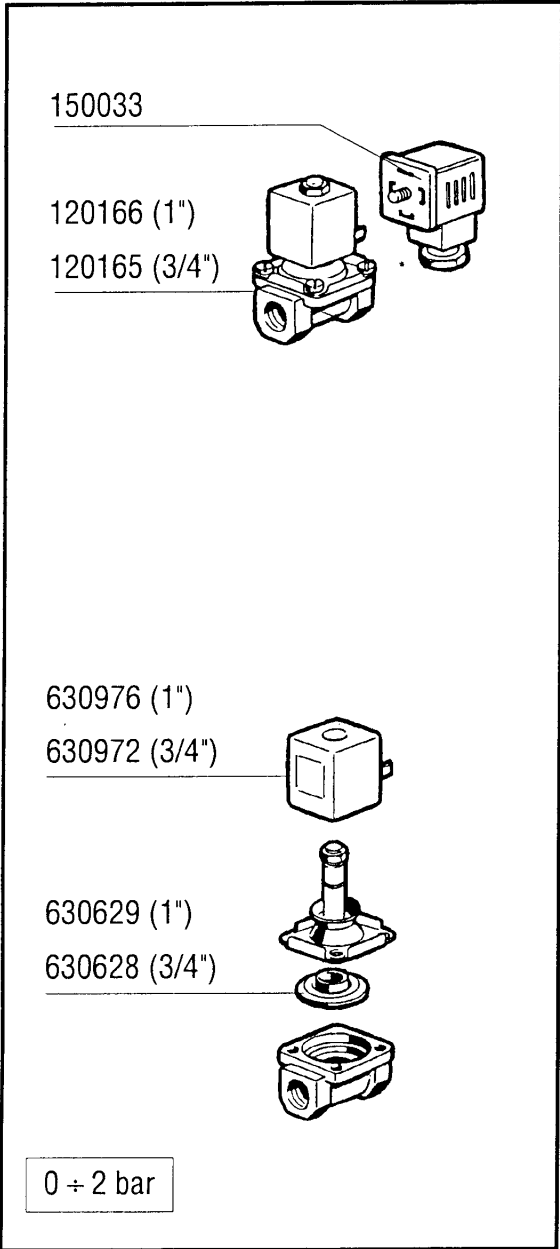

15 - Steam solenoid valve

CODE	DESCRIPTION
120162	SOLENOID VALVE L145R1Z734A 3/4
120163	SOLEN.VAL.ST.L145R1Z234A 1"24V
120165	SOLEN.VALVE ST.24V50HZ 3/4"
120166	STEAM SOLEN.VALVE 1" 24V-50
150033	CONNEC.F.SOLEN.VALVE 182.09.N
630625	KIT F.SOLEN.VALVE
630626	KIT FOR SOLENOID VALVE 145 1"
630628	KIT F.SOLEN.V.L153D1 3/4"
630629	KIT SOLENOID VALVE 1" STEAM L1
630972	COIL Z534A/V.24-L145A-3/4
630973	COIL Z614A/V.24-L145-3/4 A
630976	COIL Z114A/V24/50HZ L153-1"

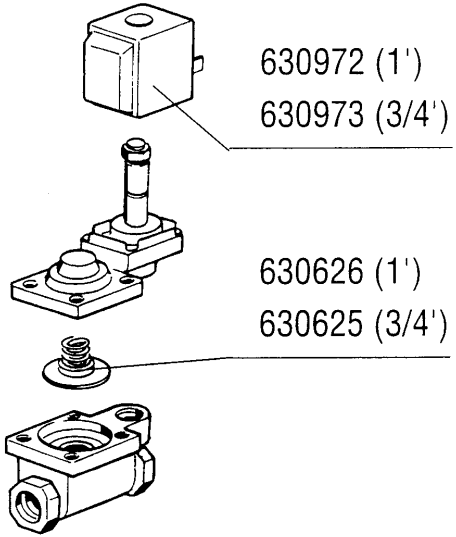
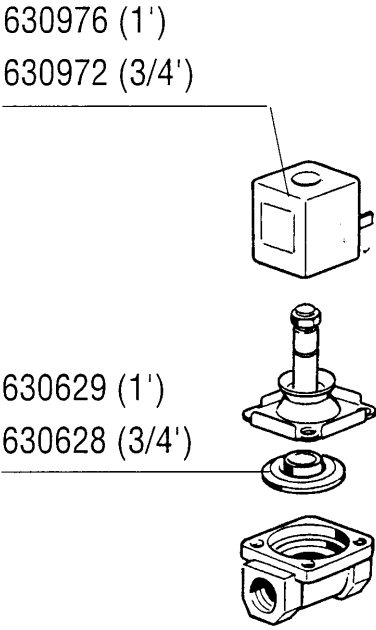
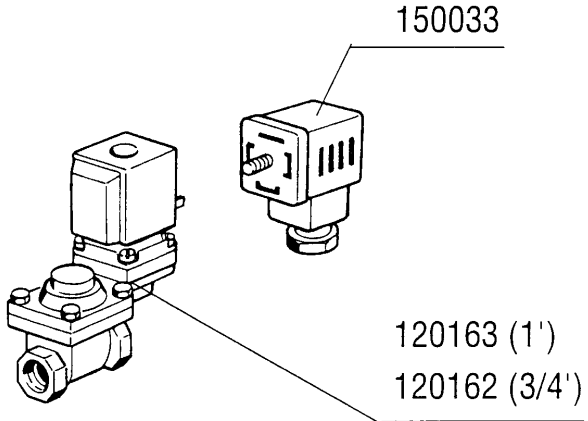
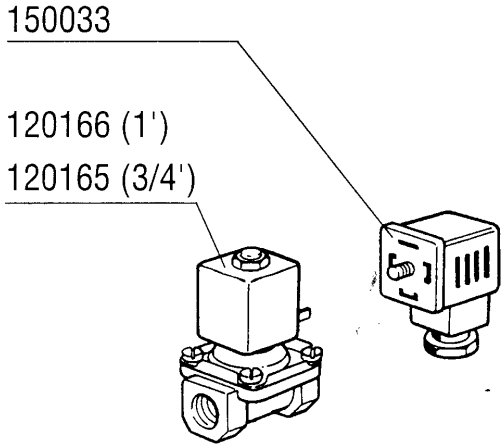

0 ÷ 2 bar

0,5 ÷ 2,5 bar

16 - Steam solenoid valve

CODE	DESCRIPTION
120162	SOLENOID VALVE L145R1Z734A 3/4
120163	SOLEN.VAL.ST.L145R1Z234A 1"24V
120165	SOLEN.VALVE ST.24V50HZ 3/4"
120166	STEAM SOLEN.VALVE 1" 24V-50
150033	CONNEC.F.SOLEN.VALVE 182.09.N
630625	KIT F.SOLEN.VALVE
630626	KIT FOR SOLENOID VALVE 145 1"
630628	KIT F.SOLEN.V.L153D1 3/4"
630629	KIT SOLENOID VALVE 1" STEAM L1
630972	COIL Z534A/V.24-L145A-3/4
630973	COIL Z614A/V.24-L145-3/4 A
630976	COIL Z114A/V24/50HZ L153-1"

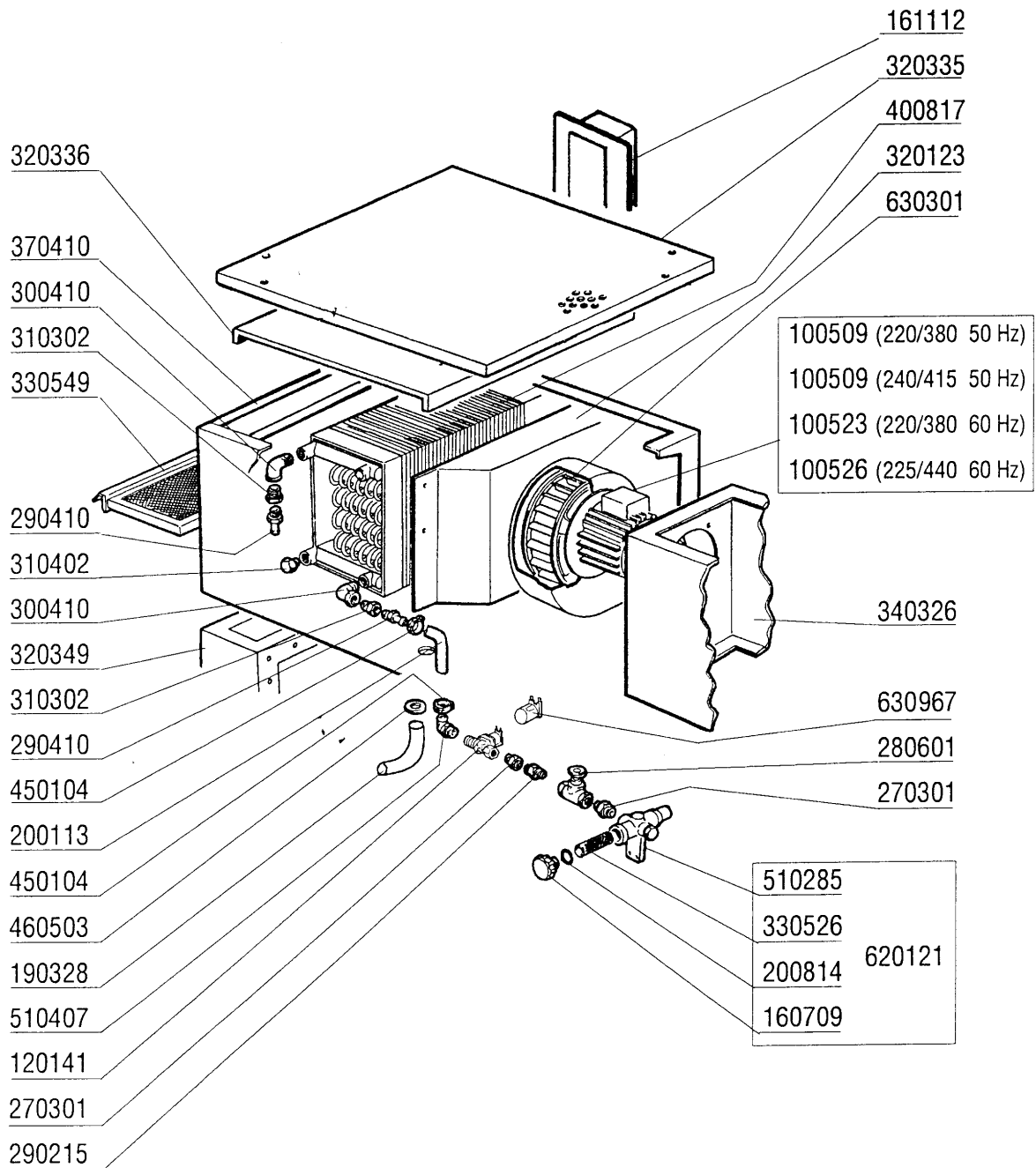

17 - Steam Condenser

CODE	DESCRIPTION
100509	FAN 0,75HP 220/415 V164/2
100523	FAN 0,75 HP 220/380V-60HZ
100526	FAN HP 0,75 255/440-60-VR184
120141	SOLEN.VALVE METAL.328000 D.1/2
160709	KNOB OF MANIFOLD F. SOLEN. VAL
161112	BACK COVER CHANNEL 300 S N
190328	DRAIN 3/4"
200113	RUBBER HOSE 12 X 22
200814	O-RING 34,52X41,58X3,53
270301	BRASS NIPPLES 1/2"
280601	GATE VALVE 1/2" BRASS
290215	1/2"BSP M/F UNION BRASS
290410	NIPPLE 1/2"
300410	ELL 3/4" MF
310302	NIPPLE 3/4"-1/2"
310402	PLUG 3/4"
320123	VORTEX BREAKER F.STEAM CONDENS
320335	TOP PANEL FOR STEAM CONDENSER
320336	TOP PANEL FOR STEAM CONDENSER
320349	TOP FOR SPLASH HOOD WITH STEAM
330526	FILTERS 22X28 SOLENOID V.MANIF
330549	CONDENSATE UNIT FILTER
340326	PANEL
370410	CONDENSER MODULE
400817	BATTERY FOR STEAM CONDENSER +
450104	CLAMP FE ZN H=12,5 15-24
460503	SEALING WASHER 38X27X2(3/4)
510285	SOLENOID VALVE MANIFOLD - BRAS
510407	NIPPLE FOR BOILER N S
620121	TWIN SOLENOID VALVE MANIFOLD
630301	FAN IMPELLOR FOR 100509
630967	COIL V24/50HZ E/V 328002

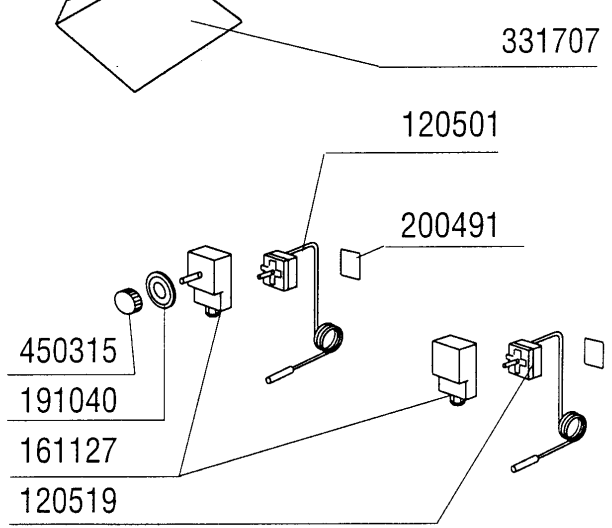
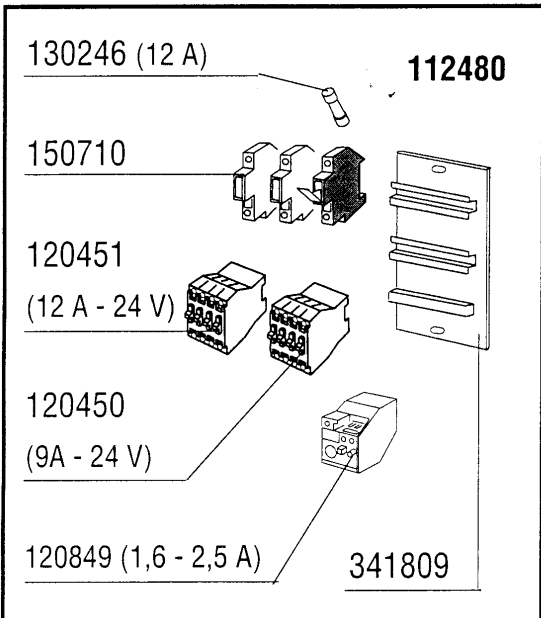
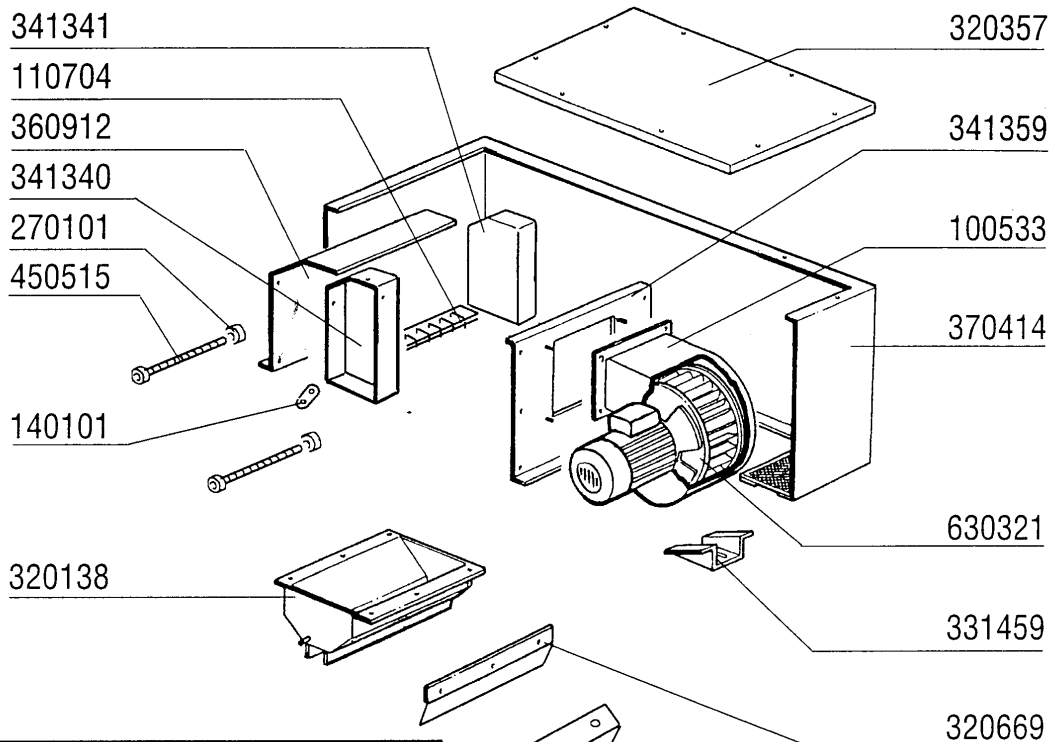

18 - Blower Dryer

CODE	DESCRIPTION
100533	FAN HP 1 220-240-380-415V VRP2
110704	HEAT.ELEMENT/DRYING 1000W 220V
112480	WIRING DRYER "AC91/101/95/105"
120450	CONTACTOR 9A 24V 4KW
120451	CONTACTOR 12A 24V 5,5KW
120501	THERMOSTAT 30/90°C
120519	SECURITY THERMOSTAT 95-125°C
120849	OVERLOAD RELAY 1,6/2,5A
130246	FUSE 10.3X38 12A GF13312
140101	BRASS CONNECT. PLATE HEAT.ELEM
150710	FUSE CARRIER 10,3X38 ART.21401
161127	BOX FOR THERMOSTAT
191040	FRAME F.THERMOSTAT KNOB
200491	BACK GASKET OF THERMOSTAT BOX
270101	HEXAGON LOCK NUT 1/2"
320138	DEFLECTOR F. DRYER
320357	DRYER COVER
320669	FIXING PLATE
331459	BRACKET FOR DRYING VENTILATOR
331707	BRACKET
341340	LEFT SUPPORT
341341	RIGHT SUPPORT
341359	FAN SUPPORT
341809	DRYER SUPPORT AC
360912	BACK PANEL
370414	DRYING MODULE
450315	KNOB F. THERMOSTAT 90°C
450515	STAINL.ST.SHIELD FOR 1 THERMOS
630321	FAN IMPELLOR FOR C 100533 1HP